



# **RFT / RCF** **Tube Fryers**

## Standard Features:

- ◆ All stainless steel front and sides.
- ◆ 25 lb, 25/25 lb., 50 lb., 60 lb., 75 lb. fry compound capacity floor units.
- ◆ 25 lb. fry compound capacity in counter unit (RCF-25).
- ◆ No flue assembly required.
- ◆ Large frying area.
- ◆ 304 S/S vessel.
- ◆ Cast iron burners each rated @ 38,000 BTU/hr. on RFT series, 18,000 BTU/hr. burner on the RCF.
- ◆ Millivolt control system with 100% safety shut-off.
- ◆ Thermostatic control with 200° - 400° F range.
- ◆ Twin fry baskets with plastic coated handles for ease of handling.
- ◆ 6" adjustable legs on the RFT series ; 4" heavy duty adjustable legs on the RCF counter top model.



**RFT-50**  
Shown On  
Optional Casters

## Optional Features:

- ◆ Casters, set of 4 (2 locking, 2 swivel)
- ◆ Extra Standard Sized Baskets
- ◆ Full Size Basket
- ◆ Quick Disconnect (3/4" gas hose with restraining device)
- ◆ S/S Joiner Strips (Connect two adjacent units)
- ◆ S/S Cover
- ◆ S/S Splash Guard (Easily removable with no special tools)
- ◆ Drain Station, matches fryer with cabinet storage below ( includes pan with screen and Heat Lamp).



**RCF-25**  
Shown

*Royal Tube Fryers are designed for easy maintenance and maximum performance at an affordable cost. The heavy gauge 304 stainless steel vessel is solidly constructed for durability and the integral tubes efficiently transfer heat for fast start up and recovery. Controls are located for convenience in operation, the large 1-1/4" diameter oil drain valve is positioned to drain oil faster without interfering with fryer controls. The sides, front, door and top are constructed of easily cleaned stainless steel.*



## ***Tube Fryer Specifications***

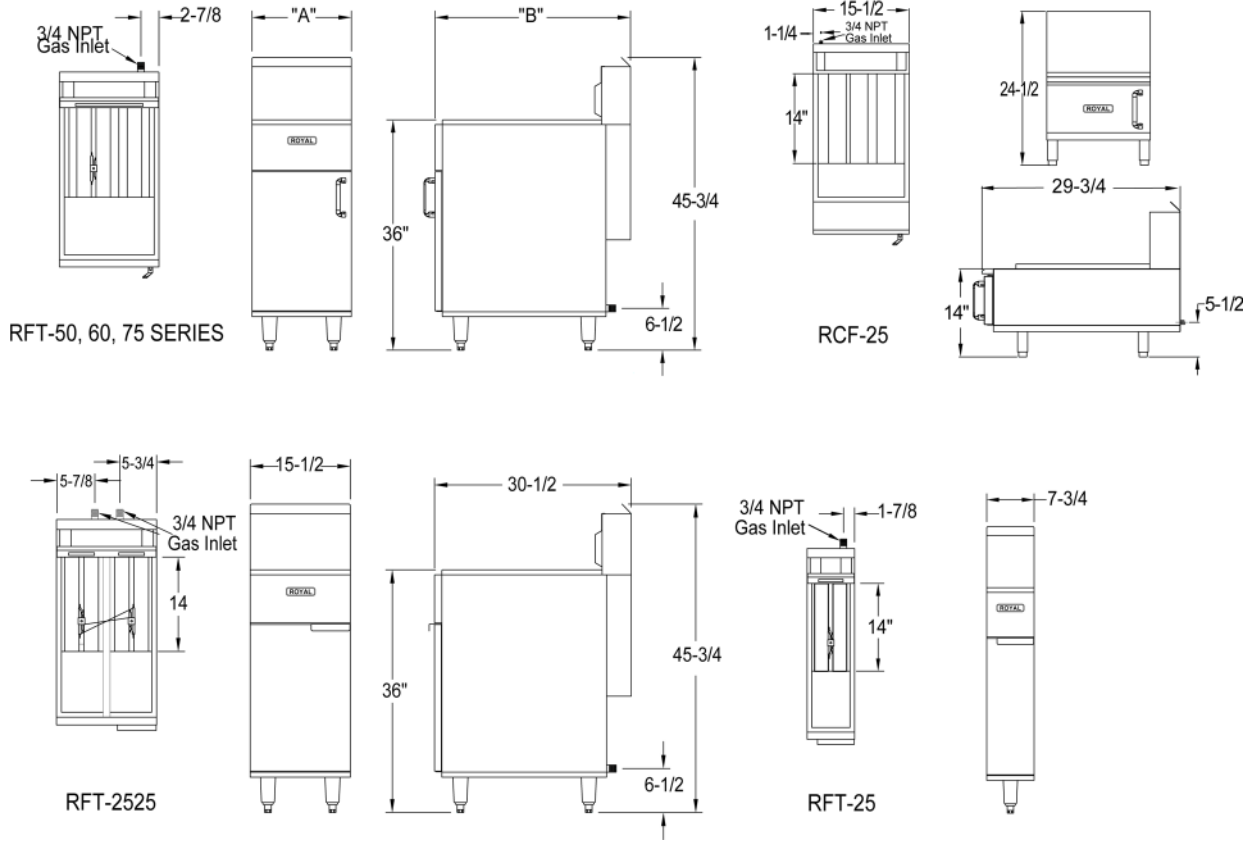

<b>Floor models</b>						
Model:	Width (A)	Depth (B)	Cooking Area	Number of Burners *	Total BTU	Ship Weight
RFT-25	7-3/4"	30-1/2"	6-3/4" x 14"	2	76,000	115 lbs
RFT-2525	15-1/2"	30-1/2"	6-3/4" x 14" 6-3/4" x 14"	4	152,000	230 lbs
RFT-50	15-1/2"	30-1/2"	14" x 14"	3	114,000	210 lbs
RFT-60	19-1/2"	30-1/2"	18" x 14"	4	152,000	275 lbs
RFT-75	19-1/2"	34-1/2"	18" x 18"	4	152,000	350 lbs
* Cast iron burners rated @ 38,000 BTU/hr.						
<b>Gas Connection: 3/4" NPT. on the right hand rear of the appliance</b>				<b>Gas pressure: 4" W.C. -Natural Gas</b>		
<b>No External pressure regulator required.</b>				<b>11" W.C. -Propane</b>		
<b>Drain Station</b>						
Model:	Width	Depth				Ship Weight
RF-DS	15-1/2"	30-1/2"				130 lbs
<b>Counter top model</b>						
Model:	Width	Depth	Cooking Area	Number of Burners *	Total BTU	Ship Weight
RCF-25	15-1/2"	29-3/4"	14" x 14"	3	54,000	80 lbs
<b>Gas Connection: 3/4" NPT. on the left hand rear of the appliance</b>				<b>Gas pressure: 4" W.C. -Natural Gas</b>		
<b>No External pressure regulator required.</b>				<b>11" W.C. -Propane</b>		

**Combustible Clearances:**

6 inches sides  
6 inches rear

**Non-combustible Clearances:**

0 inches sides  
0 inches rear

**Specify type of gas and altitude, if over 2,000 feet, when ordering.**

*Due to continuing product development to ensure best possible performance, these specifications are subject to change without prior notification*

3245 CORRIDOR DR. MIRA LOMA, CA. 91752 951.360.1600 FAX 951.360.7500 (01/09)